

WINTER

Precision Grinding Solutions

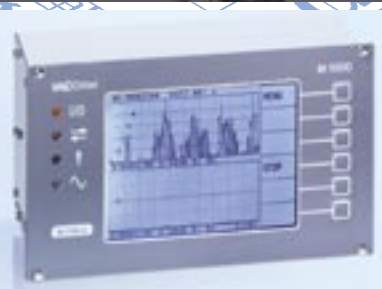

MDress - the high precise mobile dressing system for grinding tools

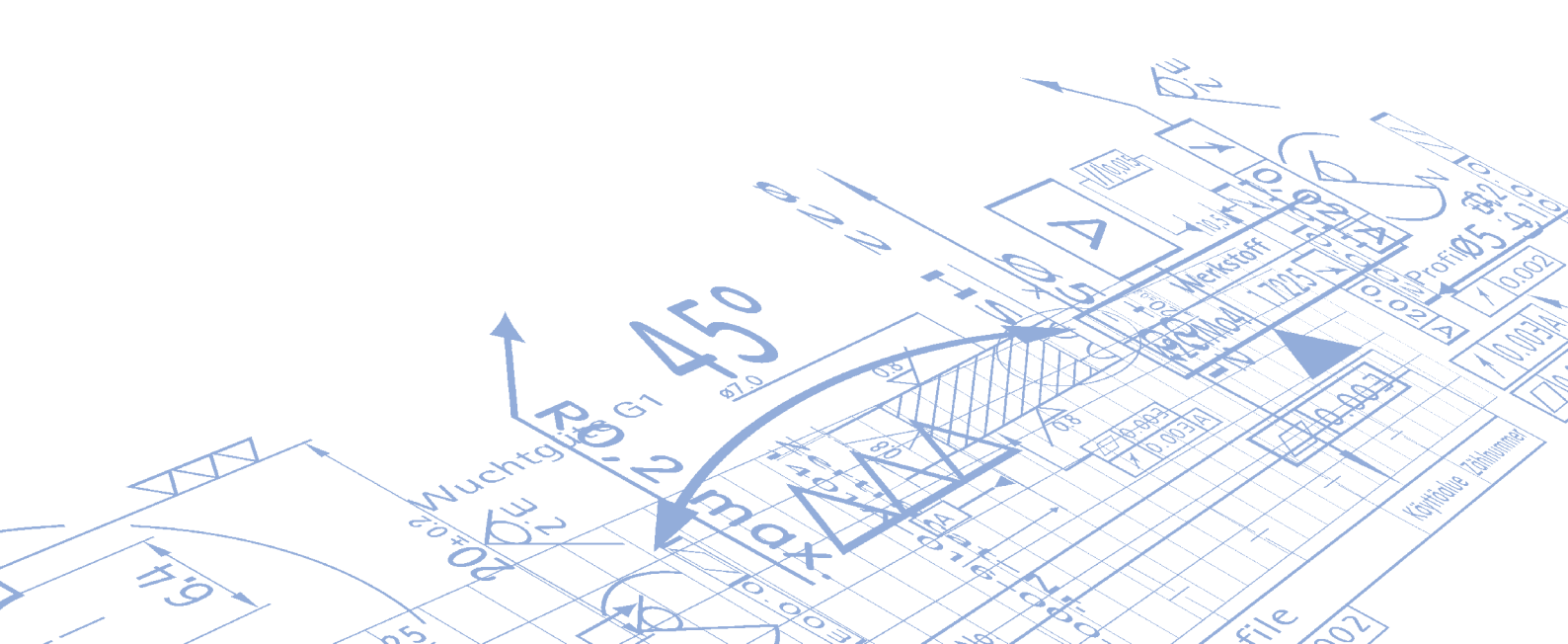

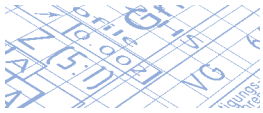

MDress – the mobile dressing system for high precise dressing

Basics of the dressing technology

The preparation of grinding tools is essential in order to create the topography and geometry of grinding wheels to an optimum for the grinding process.

This conditioning process includes trueing, sharpening and cleaning. By trueing the macro geometry is created, by sharpening the grit protrusion and by cleaning particles are removed, which may be left in the grinding layer during trueing or sharpening.

Conditioning		
DRESSING		CLEANING
Trueing	Sharpening	Microstructure
generating the runout and tool profile	create the topography	remove the chips
effecting of the grit and the bond	build up the grit protrusion	no effect by grinding wheel

Acoustic emission (AE)

With this method of contactless measuring and the visualization on a screen a decrease of loss of the grinding layer during dressing is achievable. Minimized dressing amounts combined with an optimized dressing and grinding cycle are guaranteeing a high process capability as well as a significant reduction of tool costs.

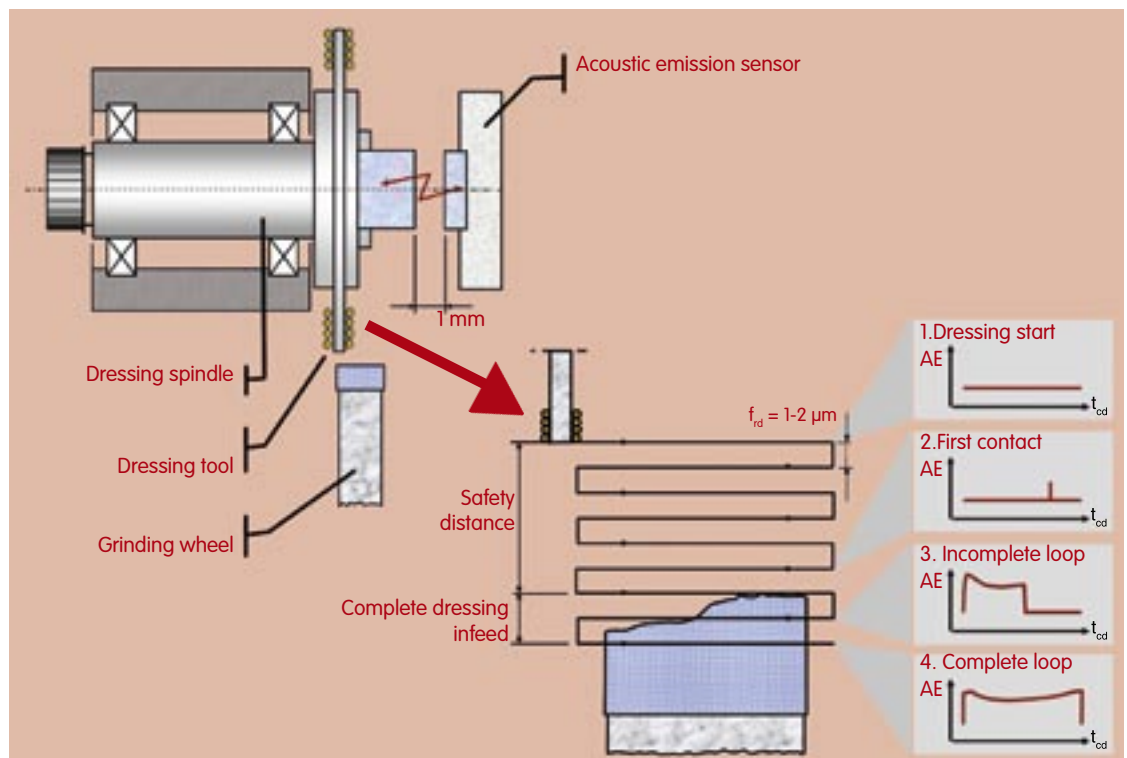

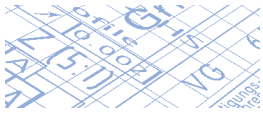

Basically components of the MDress dressing system

MDress suitcase with components

- 1) Dressing spindle
- 2) Frequency converter
- 3) Winter DDS dressing roller
- 4) Oil separator
- 5) Instruction handbook
- 6) Accessories
- 7) Acoustic emission system



Connecting of the system components



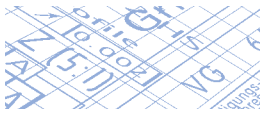

MDress - for machines without rotating dressing tool

Dimensions and details

Dimensions of STEINMETZ fitting

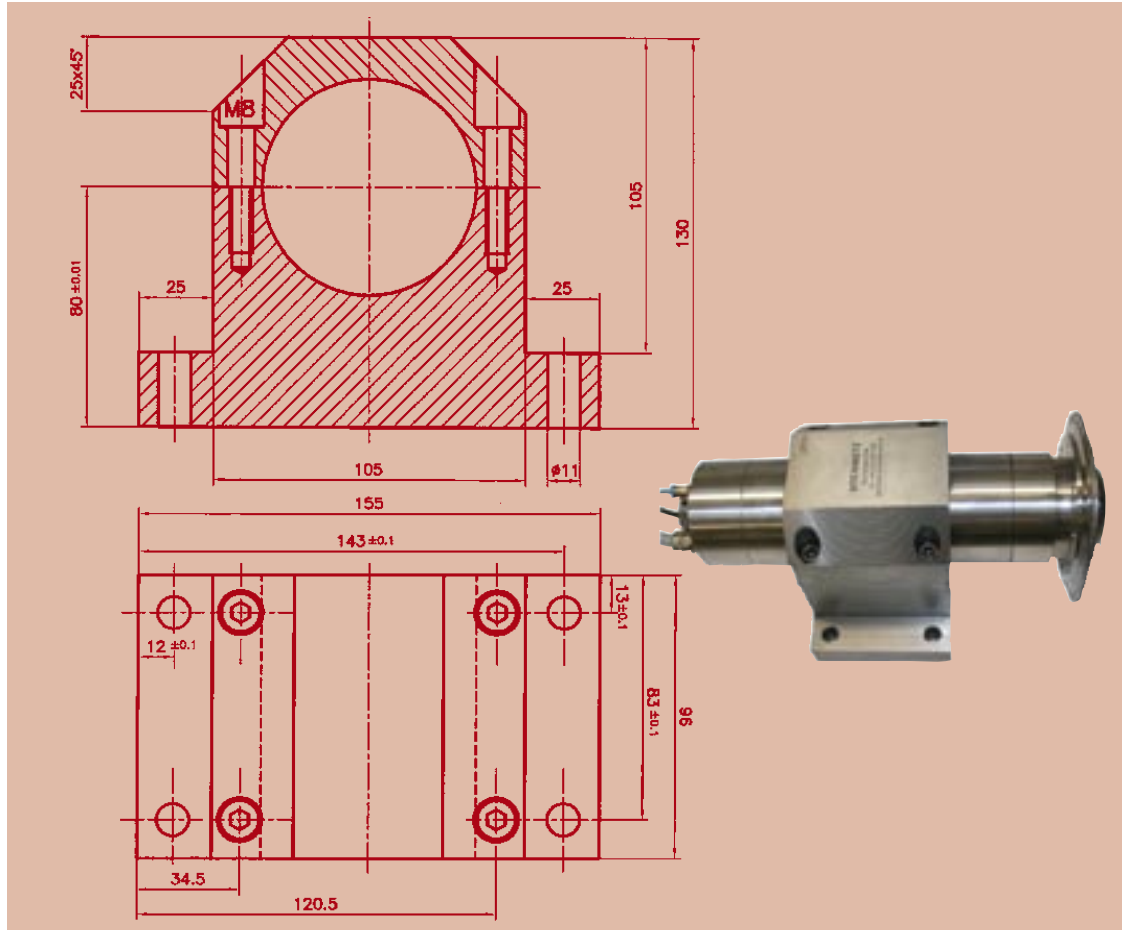

Technical details – WINTER DDS dressing roller

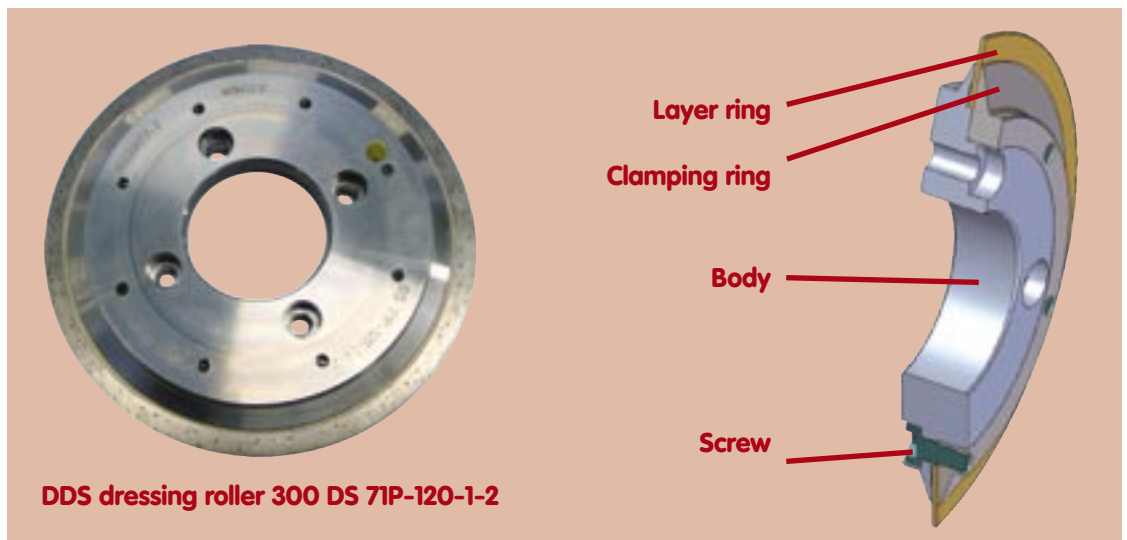

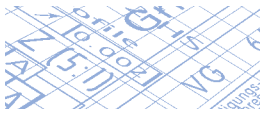

MDress – powerful, flexible, fast, a practically dressing system

Process monitoring

DITTEL acoustic emission (AE)

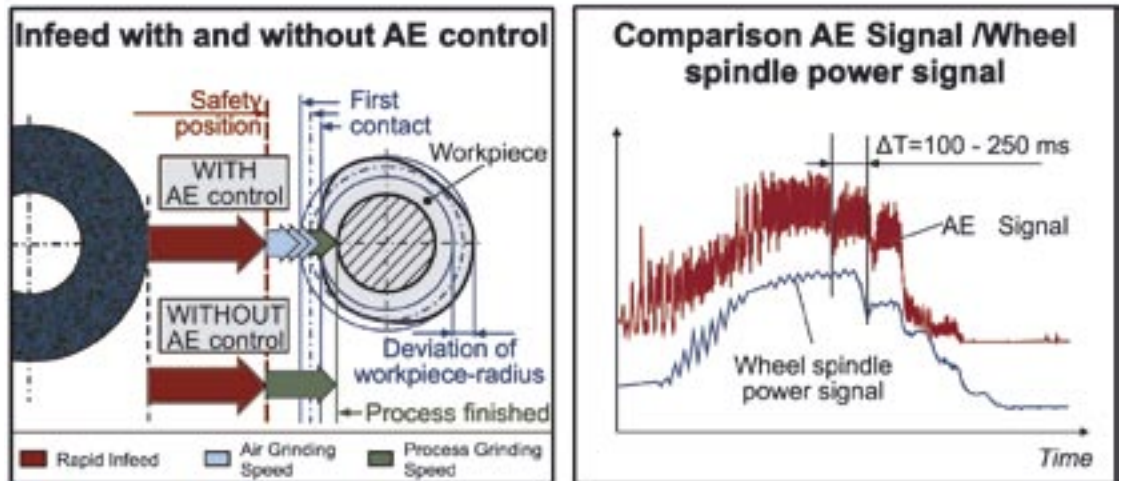

Acoustic emission (AE) is a highly dynamic, fast signal with a large number of characteristic process values.

The quality of the measured signal depends on the mounting distance of the sensor to the source of the acoustic emission. It has to be fixed as close as possible to the point of contact between dresser and grinding wheel.

Life time and product life

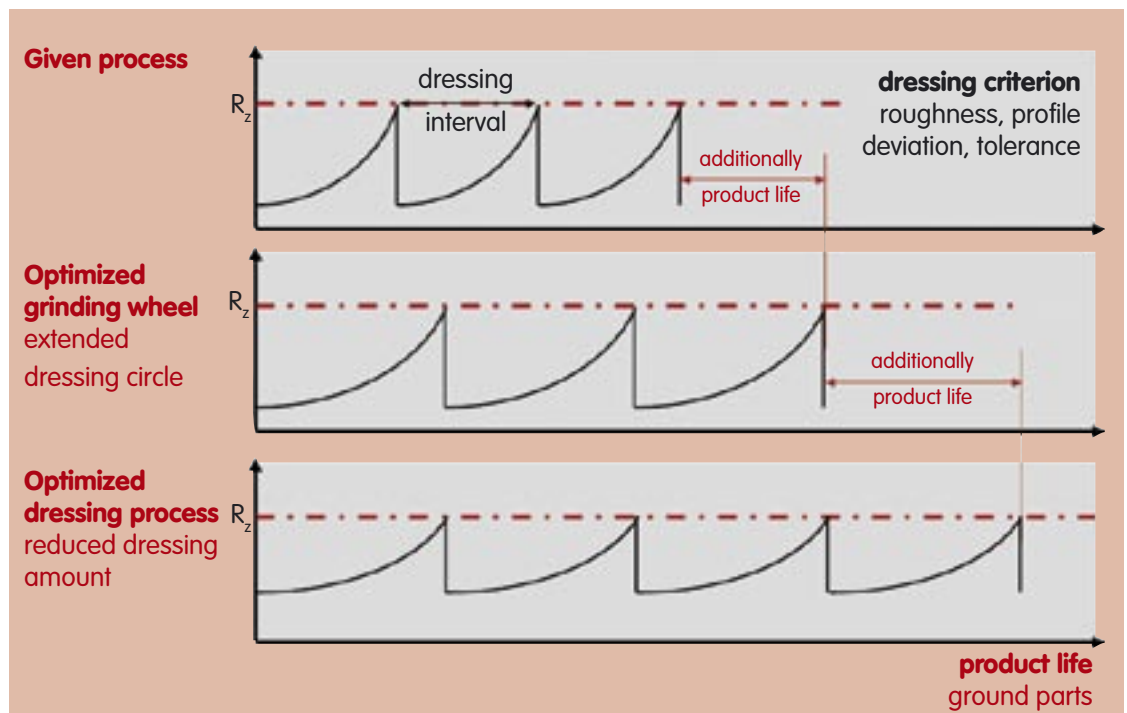

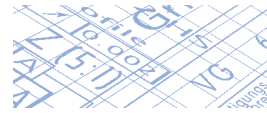

Advantages of Touch-Dressing versus conventional methods

Saving of time and increasing of life time

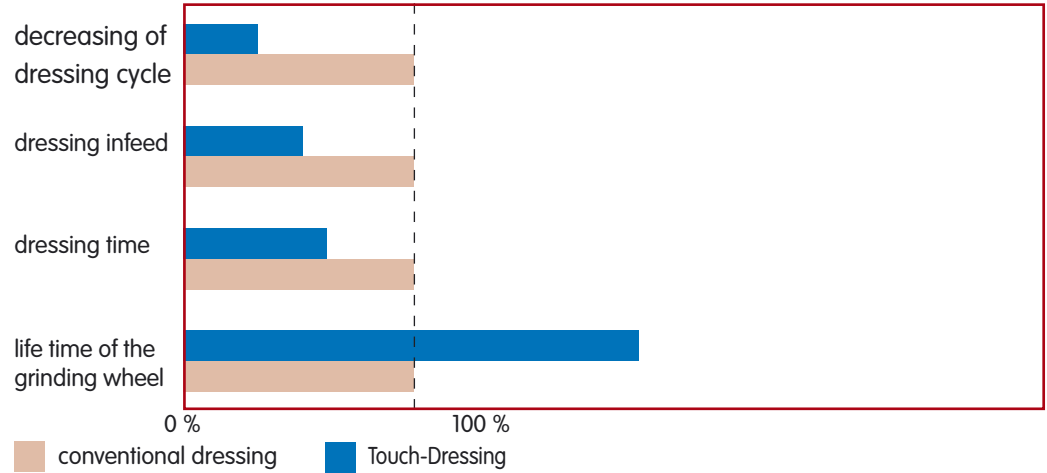

Local service

Our service engineers will assist to install a dressing process with the MDress locally on your machine, by request. Please contact:

Phone +49 (0)40 5258-0 oder E-mail: hans-ulrich.hettner@saint-gobain.com

Of course the MDress device is acquisition able for long term using, as well. Price on request.

Examples of applications



SAINT-GOBAIN
Diamantwerkzeuge
GmbH & Co. KG
Schützenwall 13-17
D-22844 Norderstedt
P.O.Box 2049
D-22841 Norderstedt
Tel.: +49 (0)40-52 58-0
Fax: +49 (0)40-52 58-215
Internet:
www.winter-superabrasives.com
E-mail:
info-winter@saint-gobain.com

Information of the dressing system and components are to find:



STEINMETZ Schleiftechnik (Abrichtspindel)
An den Hirtenäckern 2, 63791 Karlstein/M., Germany
Tel.: +49 (0)6188 7495, Fax: +49 (0)6188 7495
E-Mail: info@steinmetz-schleiftechnik.de



Walter Dittel GmbH
Erpffinger Straße 36, 86899 Landsberg am Lech, Germany
Tel.: +49 (0)8191 3351-155, Fax: +49 (0)8191 3351-9155
www.dittel.com
E-Mail: info@dittel.com